

- DTA114EK
- DTA124EK
- DTA144EK
- DTC114TK
- DTC114YK
- DTC124EK
- DTC143TK
- DTC144EK
- 2SA1036K
- 2SC2412K

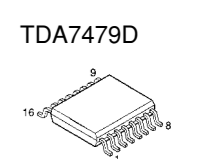
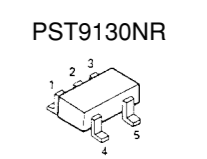
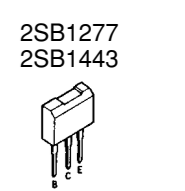
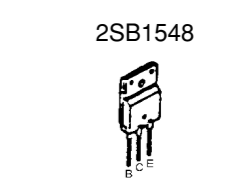
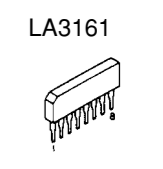
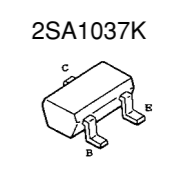

CAUTION: For continued safety, replace safety critical components only with manufacturer's recommended parts (refer to parts list). indicates safety critical components. For continued protection against risk of fire, replace only with same type and rating fuse(s). To reduce the risk of electric shock, leakage-current or resistance measurements shall be carried out (exposed parts are acceptably insulated from the supply circuit) before the appliance is returned to the customer.

Manufactured under license from Dolby Laboratories. "Dolby" and the double-D symbol are trademarks of Dolby Laboratories.

IC1	: *	Q49,50,52,57,61,500,503
IC2	: TDA7400D	: 2SC2412K or 2SD601A
IC3	: HD74HC27FP	: DTA7384A
IC4	: TDA7384A	: Q51,261 : 2SB1443
IC5	: LA3161	: Q53 : 2SA1036K
IC6	: PST9130NR	: Q54,58 : DTC144EK or UN2213
IC7	: TDA7479D	: Q55,59,153,352,502 : DTA124EK or UN2112
		: Q56,60 : 2SB1655(E,F) or 2SB1565(E,F)
		: Q150 : DTC124EK or UN2212
		: Q151,260,353 : DTC114YK or UN2214
		: Q201,203,350 : 2SB1277(Q,R)
		: Q301 : DTA144EK or UN2113
		: Q320,351 : 2SA1037K or UN2212
		: Q450,451 : DTC143TK or UN2216
		: Q501 : DTC114TK or UN2215

MODEL NAME	UNIT NO.	(A)	D350	D370	R103	R104	R370	IC1
KRC-281RS (M)	0-20	YES	YES	NO	NO	YES	NO	UPD780058Gxxxx
KRC-179RA(G) (E)	2-71	NO	NO	NO	NO	YES	NO	UPD780058G2112
KRC-179RYA(YG) (E)	2-71	NO	NO	YES	YES	NO	YES	UPD780058G2111
KRC-15R (G)	2-71	NO	NO	YES	YES	NO	YES	UPD780058G2111
KRC-279RA(G) (E)	2-72	YES	NO	YES	NO	YES	YES	UPD780058G2111
KRC-279RYA(YG) (E)	2-72	YES	NO	YES	NO	YES	YES	UPD780058G2111
KRC-25RA(G) (E)	2-72	YES	NO	YES	NO	YES	YES	UPD780058G2111

KRC-15R,179R,25R,279R,281R

KENWOOD

SWITCH UNIT (X13-964x-xx)

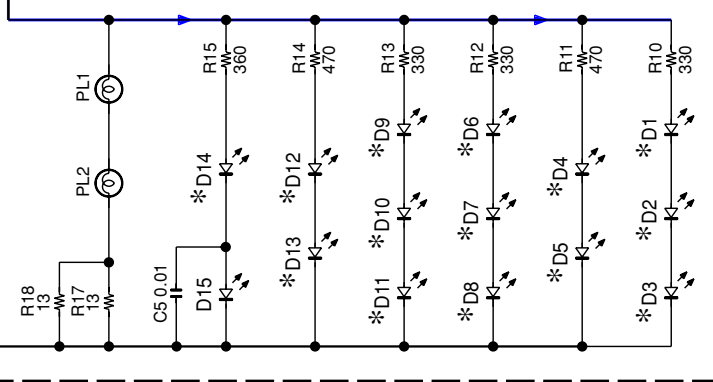
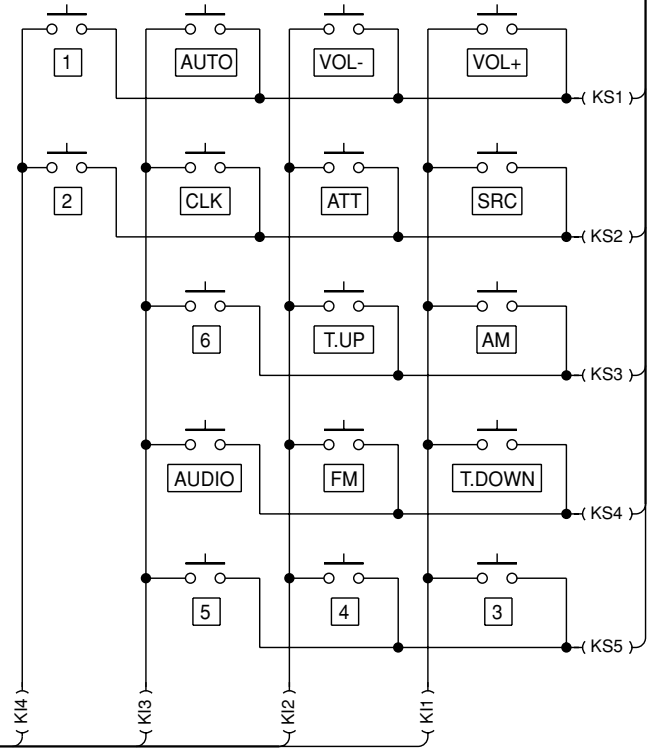
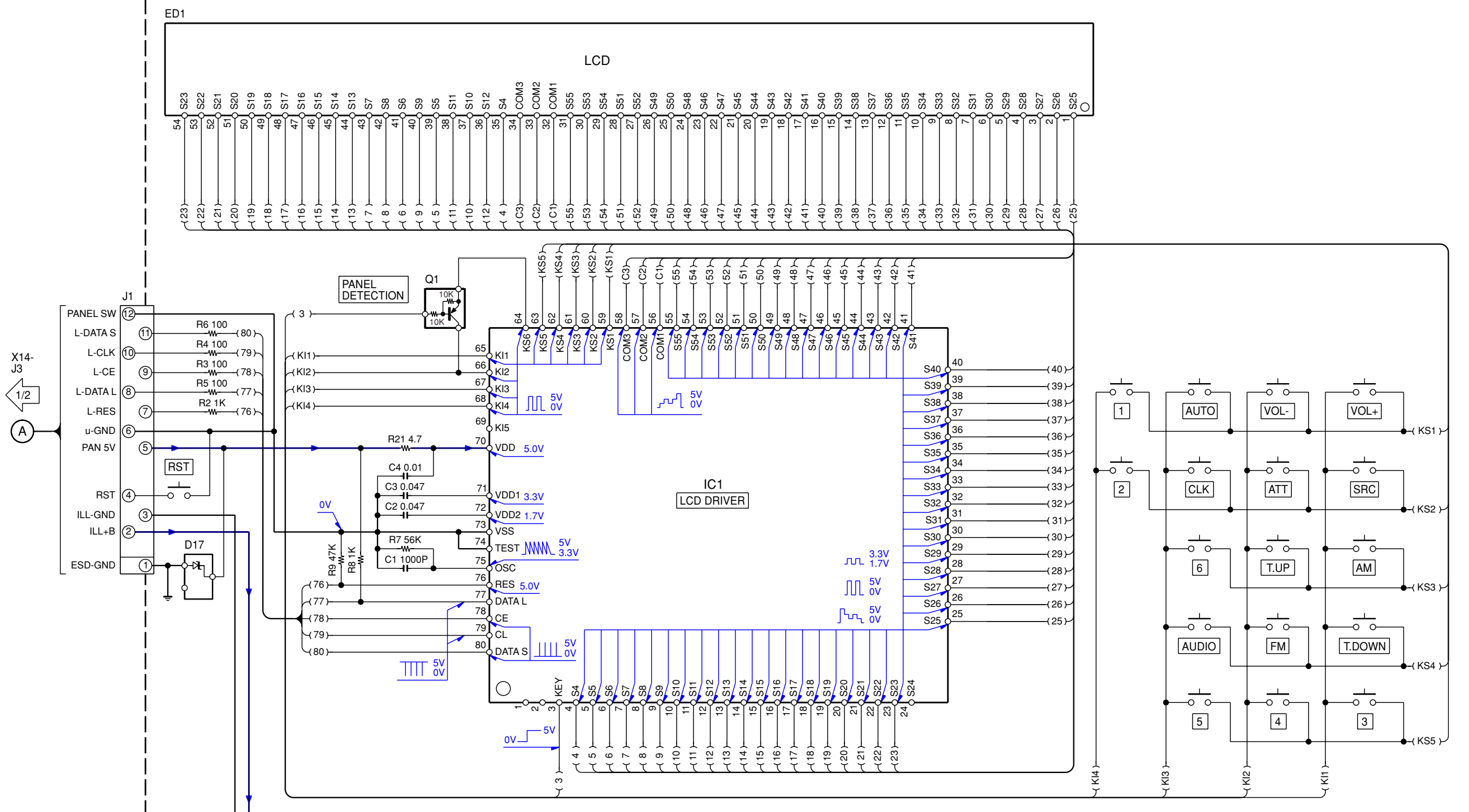

(X13-964x-xx)

MODEL NAME	UNIT No.	D1-13	D14
KRC-281RG (M) KRC-279RG (E) KRC-279RYG (E) KRC-179RG (E) KRC-179RYG (E) KRC-25RG (E) KRC-15RG (E)	0-21	B30-1565-05 (GREEN)	B30-2025-05 (GREEN)
KRC-279RA (E) KRC-279RYA (E) KRC-179RA (E) KRC-179RYA (E) KRC-25RA (E)	2-72	B30-1566-05 (RED)	B30-1511-05 (RED)

- IC1 : LC75883E
- Q1 : DTA114EK
- D1-13 : *
- D14 : *
- D15 : B30-1564-05
- D17 : MA3062-M

— GND LINE
— +B LINE

CAUTION: For continued safety, replace safety critical components only with manufacturer's recommended parts (refer to parts list), indicates safety critical components. For continued protection against risk of fire, replace only with same type and rating fuse(s). To reduce the risk of electric shock, leakage-current or resistance measurements shall be carried out (exposed parts are acceptably insulated from the supply circuit) before the appliance is returned to the customer.

Manufactured under license from Dolby Laboratories.
"Dolby" and the double-D symbol are trademarks of Dolby Laboratories.