



2.5 kW MMA welding machine

Introduction

In this application note a power AC-DC converter, suitable to be used as the current supply for the MMA welding process, is described.

The MMA welding method is the most common method used for welding iron or steel. Usually this method, also the most simple, is dedicated to small home repairs but also to light professional use.

In recent years, the availability of low cost and reliable solutions, based on power electronics, has moved the approach to this application from a standard magnetic solution, based on a low frequency iron transformer, to a high frequency switching solution. This gives the possibility of having compact and light solutions at a relatively low price. The electronic control used on modern welding machines allows a simple and safe use, so even an unskilled person can use it with good results in terms of weld quality.

Contents

1	MMA welding process	4
2	MMA welding power supply	6
3	State of the art forward converter	8
4	Current control implementation	9
5	Welding machine hardware	11
5.1	Power board description	11
5.1.1	Power board schematic description	12
5.2	Control board schematic description	15
6	Revision history	18

List of figures

Figure 1.	MMA welding process.	4
Figure 2.	Output characteristic of an MMA welding power supply	5
Figure 3.	Schematic diagram of a double switch asymmetric forward converter.	6
Figure 4.	Some significant acquired waveforms	7
Figure 5.	Block diagram of current control circuit.	9
Figure 6.	MMA welding machine demonstration board STEVAL-ISW001v1 (side view)	11
Figure 7.	MMA welding machine demonstration board STEVAL-ISW001v1 (top view)	12
Figure 8.	Power board schematic	14
Figure 9.	Control board schematic.	15

1 MMA welding process

In the following paragraph a general description of the Manual Metal Arc (MMA) welding process is explained.

The process is very simple. A plasma arc, able to generate a very high temperature in a restricted area, is used to fuse iron or metal.

The plasma arc is created by a high current at low voltage. Two wires, one fixed to the iron or metal pieces to be welded by a metallic clamp, and one with a special tool on its end called an electrode holder, and able to fix a metallic rod, are used to be connected to the power supply's negative and positive outputs, respectively.

A shielded electrode is used at the same time to conduct the current, necessary to sustain the plasma arc and to introduce additional welding material into the welding area.

The electrode is shielded by a particular material that assures, when melted, the production of an inert gas environment to protect the weld from an immediate oxidation process due to high temperatures.

In [Figure 1](#) the MMA process outline is shown.

In order to switch on a high temperature low voltage plasma arc, necessary to weld, a current source able to provide a high current level at low voltage is required.

Starting from the AC net (185 Vac to 265 Vac) the system must perform a conversion from AC to DC and from high voltage to low voltage. Proportionally, by fixing a maximum power from the main, the output supplied current is gained. Another important function that the welder power supply must assure is the galvanic insulation between the main net and the output ground. In fact, during the welding process the negative output is directly connected to the iron piece being welded, therefore, for safety reasons, insulation is needed.

Figure 1. MMA welding process

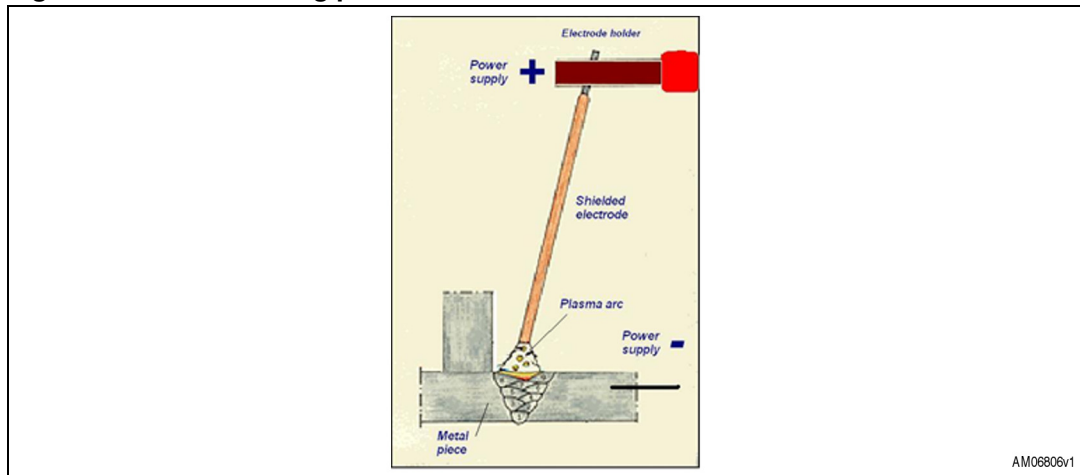

In [Figure 2](#) a classic current vs. voltage characteristic of an MMA power supply is depicted.

Figure 2. Output characteristic of an MMA welding power supply

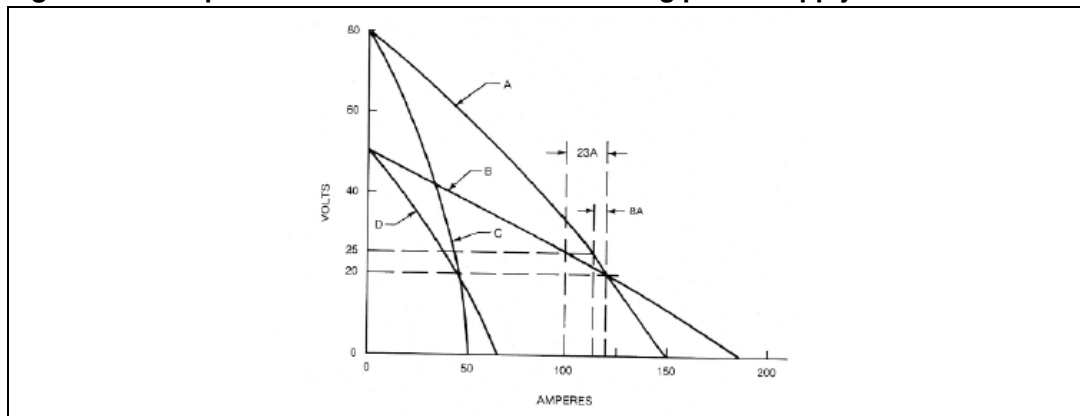

The output characteristic of a suitable MMA power supply shows that a high DC open load voltage is present on the welding torch in open circuit condition.

As soon as the current drained by the welding pool increases, the voltage decreases.

Around the welding operating point the characteristic suggests a current limited generator behavior.

The plasma arc, and so the welding process, starts when contact is made with the metal pieces, connected to ground with the electrode. In this condition a short-circuit is present at the output of the power supply. This condition has to be managed by limiting the SC (shortcut) current in order to protect the hardware against this transient.

As soon as the plasma starts, the electrode is no longer in contact with the metal, a voltage at the output of the power supply (across the plasma) appears and the welding process works by melting the iron.

In this condition, the current is still limited by the power supply at the level set by the operator according to the type and thickness of the metal piece.

2 MMA welding power supply

The following are some electrical specifications of an MMA welding power supply, for a small machine usually used in home appliances or light professional use:

- V_{in} (AC): 185 Vac to 265 Vac
- V_{out_peak} : 80 V
- I_{out_max} : 135 A
- $F_{switching}$: 70 kHz
- Efficiency: > 75 %

The topology chosen to develop this kind of power supply is a double switch asymmetrical forward converter.

This topology is suitable for high power delivered to the secondary side of a ferrite high frequency transformer and at the same time can be considered simple, cheap, and robust.

[Figure 3](#) shows a schematic diagram of a double switch asymmetrical forward converter.

Figure 3. Schematic diagram of a double switch asymmetric forward converter

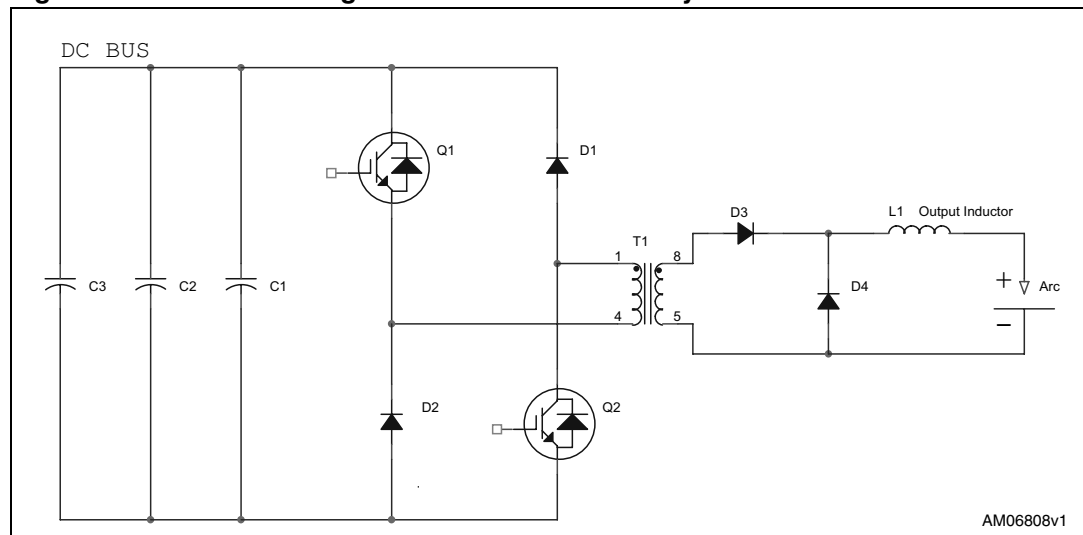

The circuit consists of two power switches used to energize the primary side of a ferrite transformer and two freewheeling diodes needed to discharge the magnetization inductance of the primary side winding of the transformer. At the secondary side, two power diodes perform the rectification. The output inductor gives a continuous-mode operation to the current.

The two power switches are switched on simultaneously allowing a current path from the high voltage DC bus. The two power switch gates are driven by a square wave with variable duty cycle. The variation in duty cycle allows the possibility to modulate the voltage on the output of the power supply and, according to this, the welding current. It is important that the duty cycle does not surpass 50 %, in order to assure a full demagnetization of the ferrite transformer during T_{OFF} period.

In [Figure 4](#) some significant waveforms are depicted.

Figure 4. Some significant acquired waveforms

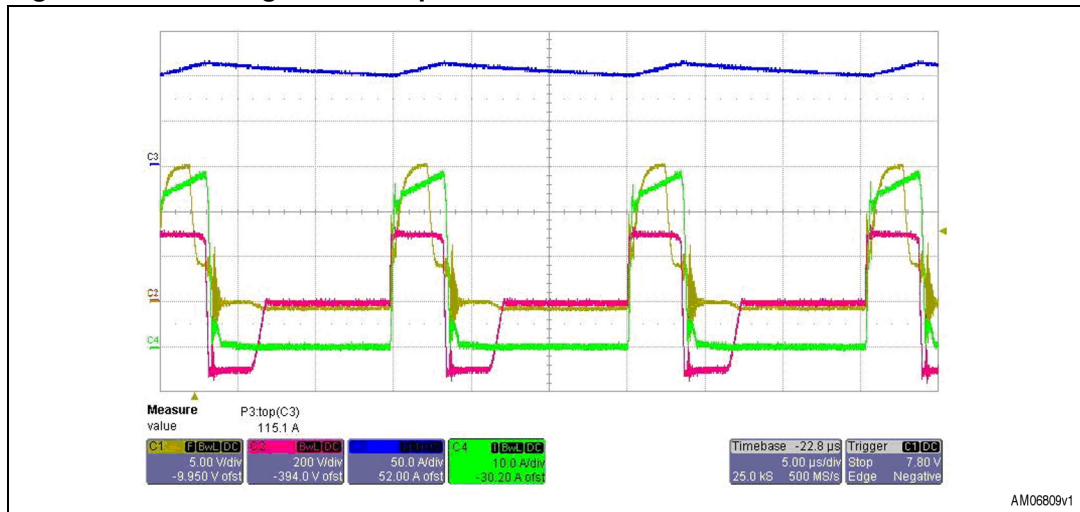

The green trace Ch4 represents the current on the power switches that during the T_{ON} switching period is the same on the primary side of the transformer. The purple trace represents the voltage across the primary side of the transformer. It may be noted that during T_{ON} the voltage is positive and equal to the DC bus voltage (around 300 V). At the end of the T_{ON} period the switches are switched off and the magnetization current of the transformer starts to circulate through the two freewheeling diodes (see the schematic in [Figure 8](#)).

The freewheeling diode action causes the inversion of the voltage across the primary side of the transformer, thanks to this the magnetization inductance can be discharged. At the end of this period, and before a new “on” period, the voltage across the transformer remains zero. For this reason, on double switch forward topology, the hard switching stress on the power devices is only the OFF transition, as during the ON transition the switches start to commutate from an intrinsic soft switching zero current condition.

The yellow trace is the gate drive signal, and above, the output current is represented with a blue trace.

3 State of the art forward converter

A forward converter is an insulated DC-DC converter that transfers the energy from the primary side of a transformer to the secondary side during the T_{ON} period of a power switch operating on the primary side.

Assuming the transformer and the power switch are ideal, during the time period T_{ON} , the diode D3 is conducting, as D4 is interdicted, (refer to [Figure 3](#)).

The voltage across the output inductor is assumed positive; the current flowing on the inductor increases linearly according to the following equations:

Equation 1

$$v_L = \frac{N_2}{N_1} V_{IN} - V_{OUT} \quad 0 < t < t_{on}$$

Equation 2

$$v_L = -V_{OUT} \quad t_{on} < t < T_S$$

Equation 3

$$\int_0^{t_{on}} v_L dt = -L \int_0^{t_{on}} \frac{di_L}{dt}$$

During the T_{OFF} time period the voltage across the output inductor is negative and equal to the output voltage. Diode D4 conducts and D3 is interdicted.

The current flowing on the inductor decreases linearly.

Assuming the voltage on the inductor is equal to zero, if integrated in the whole switching period, and assuming the duty-cycle is equal to:

Equation 4

$$\delta = \frac{t_{on}}{t_{on} + t_{off}} = \frac{t_{on}}{T_S}$$

The relationship between the input and output voltage can be expressed as:

Equation 5

$$\frac{V_0}{V_d} = \frac{N_2}{N_1} \delta$$

At this point it is simple to show that only during T_{ON} the current measured on the primary side of the transformer is directly dependent on the current on the output, so it is practically impossible to have precise control of the output current, knowing only the input current on the primary side of the transformer.

Those relationships are helpful to understand the control circuit implemented on this power supply.

4 Current control implementation

In [Figure 5](#) the block diagram of the current control circuit is shown. The suggested control method has been patented by STMicroelectronics.

Figure 5. Block diagram of current control circuit

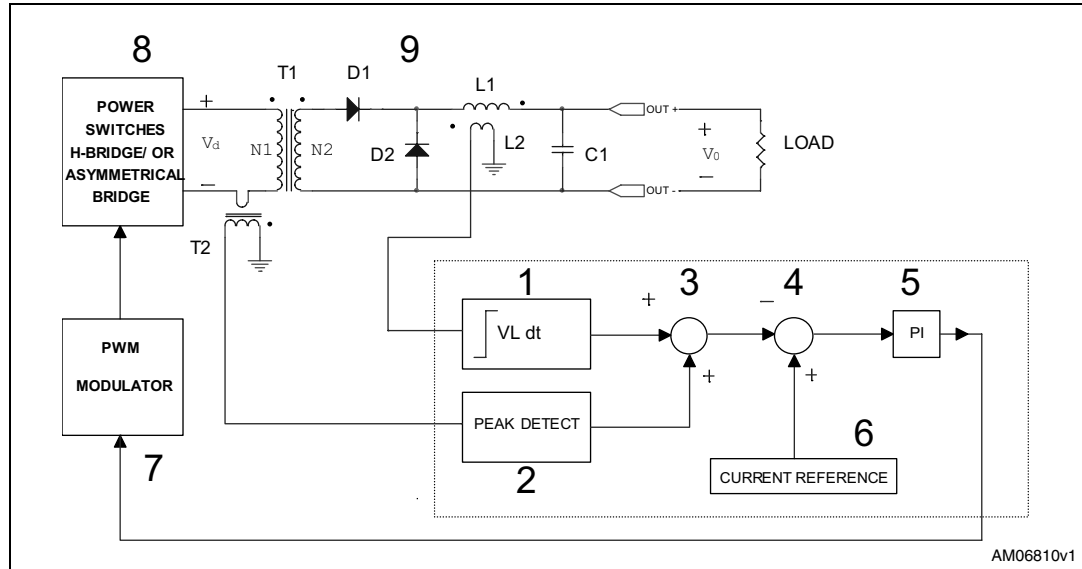

Reading only the input primary side current on the ferrite transformer is not sufficient to have a precise current control on the welding pool. In fact, the output voltage of the converter, equal to the welding voltage, is not fixed and can change during the process due to a variety of factors. The consequence is a power control on the primary side but not a current control on the output.

The patented idea is to reconstruct the waveform and value of the output current only by reading the input current on the primary side of the transformer and the output voltage reflected on the output inductor during the T_{OFF} time period of the switching cycle.

The voltage reflected across the output inductor, during T_{OFF} is the output voltage of the converter and so the voltage across the plasma welding arc during the welding process.

It is understood from the equation of the forward converter that the current on the output inductor during T_{OFF} and T_{ON} can be expressed as follows:

Equation 6

$$I_1(t) = \frac{1}{L} \int_{ton}^{Ts} v_1 dt$$

Equation 7

$$V_1 = -V_{out}$$

Equation 8

$$I_1(t) = \frac{1}{L} \int_0^{ton} v_1 dt$$

Equation 9

$$V_1 = V_{in} \frac{N_2}{N_1} - V_{out}$$

Where $T_s - T_{ON} = T_{OFF}$

The result of these integrals is a function which describes the slope of the output current during T_{ON} or T_{OFF} in particular, precious information comes from the reflect output voltage on the inductor that allows the slew rate of the current during T_{OFF} otherwise unpredictable, to be known.

In fact the output voltage isn't controlled and depends on the welding arc, as already explained above.

Remember that during T_{OFF} the diode D1 ([Figure 5](#)) is interdicted and there isn't any connection between input and output.

This means that if the voltage across the output inductor could be read, by integrating it, the slope of the output current during T_{OFF} would be known.

To solve the integral equation it is still necessary to calculate the value of the current, and integration constant, to define the border condition.

This information comes from the input current transformer that measures the peak of the input current representative of output current.

Equation 10

$$I_{out_peak} = \frac{N_1}{N_2} I_{in_peak}$$

Therefore, the key of this patented system, is to use the information from the current transformer applied on the primary side, to obtain information about the current peak on the inductor; and some signals turn on the output inductor to obtain information about the current slope, that, once the value of L is fixed, depends only on the voltage across the plasma arc.

The two pieces of information are combined together in order to have a waveform that reconstructs the output current (see [Figure 5](#)).

T2 on the primary side is the current transformer which senses the value of the input current. This information is applied at input to a peak detector circuit to freeze the peak value of the current. The voltage sensed by some turns applied on the output inductor, once integrated, give information about the output current slope.

Combining these two elements, at the output of the sum node 3 you have a scaled reconstruction of the output current (scaled due to the sensing and post processing block constant). This signal can be used in input to a classic PI regulator to control, and maintain as fixed as possible, the output current against the load and output voltage variation.

5 Welding machine hardware

Here below in figure the welding machine. This board is one of the STMicroelectronics demonstration board available on stock with the code STEVAL-ISW001v1.

Figure 6. MMA welding machine demonstration board STEVAL-ISW001v1 (side view)



The welding machine demonstration board is made up of a power board, including all the power parts and onboard power supply necessary to supply all the circuits of the system, and a control board installed on the power board through a 26-pin connector.

The control board can therefore be considered a “sister board” and can be replaced using other control methods or devices, or moved to a control based on a microcontroller, maintaining the power part unchanged.

5.1 Power board description

In *Figure 6*, on the left-hand side, the input mains section can be found, including the input EMI filter. The white screw connector is the input for the Vac mains; the green screw connector is used to connect an external fuse holder, to be installed on the rear or front panel of a suitable case that contains the hardware. From left to right, the two big heatsinks seen hold the 4 IGBT power switches. The IGBTs are paralleled, two for the high side section of the converter and two for the low side.

In the middle of the power board a small control board is installed through a double in-line connector, as previously mentioned.

On the right-hand side the output power diodes are installed.

Figure 7. MMA welding machine demonstration board STEVAL-ISW001v1 (top view)



In [Figure 7](#) the insulated ferrite transformer can be seen in the centre of the board. On the left-hand side the output coil with the signal auxiliary winding is present, necessary for the sensing of the reflected voltage.

Two copper bars with bolts are used to connect the external cable with the ground clamp and the electrode holder.

5.1.1 Power board schematic description

In [Figure 8](#), the schematic of the power board for the welding machine is depicted.

Starting from the AC mains input, you find an EMI common mode choke and the NTC necessary to limit the inrush current due to the electrolytic capacitor present after the input diodes bridge. The auxiliary power supply is based on the Viper16 and provides, using a flyback transformer, two insulated voltages. One of the two low voltages is common ground connected to power and control ground. The insulated +15 V is used to supply the high side part of the L6386E gate driver. In this case this solution was preferred to the boot strap solution because of current availability reasons.

The L6386E gate driver is also used to implement a hardware peak current protection thanks to the internal comparator present inside this gate driver.

In order to increase the current capability of the gate driver, two small integrated push-pull transistors are used (STS01DTP06), one for the high side and one for the low side power switch couple.

In series with the high frequency ferrite transformer a current transformer is inserted. The voltage across R44 is sent through a resistive partition to the Cin input of the L6386E gate driver. As soon as the voltage on this pin is equal to the fixed internal threshold of 500 mV, the gate driver shuts down the two gate outputs. In this way, a valid and fast hardware current protection is implemented to protect the power part. With the net used, the current protection is set to about 32 Apk.

The output rectification stage is made up of the power diodes D29, D30 and D31.

On the output inductor, a secondary winding is present in order to read the reflected welding voltage (voltage across the plasma arc) as previously explained.

The optocoupler U7, senses the output shortcut condition. This information is sent to the control logic to change the current reference and to start the shortcut condition delay. The trimmer R60 allows the voltage threshold to be set between the correct voltage on the plasma and recognition of the shortcut condition.

R60 should be trimmed according to some parameters such as, for example, the length of the output cable.

Figure 8. Power board schematic

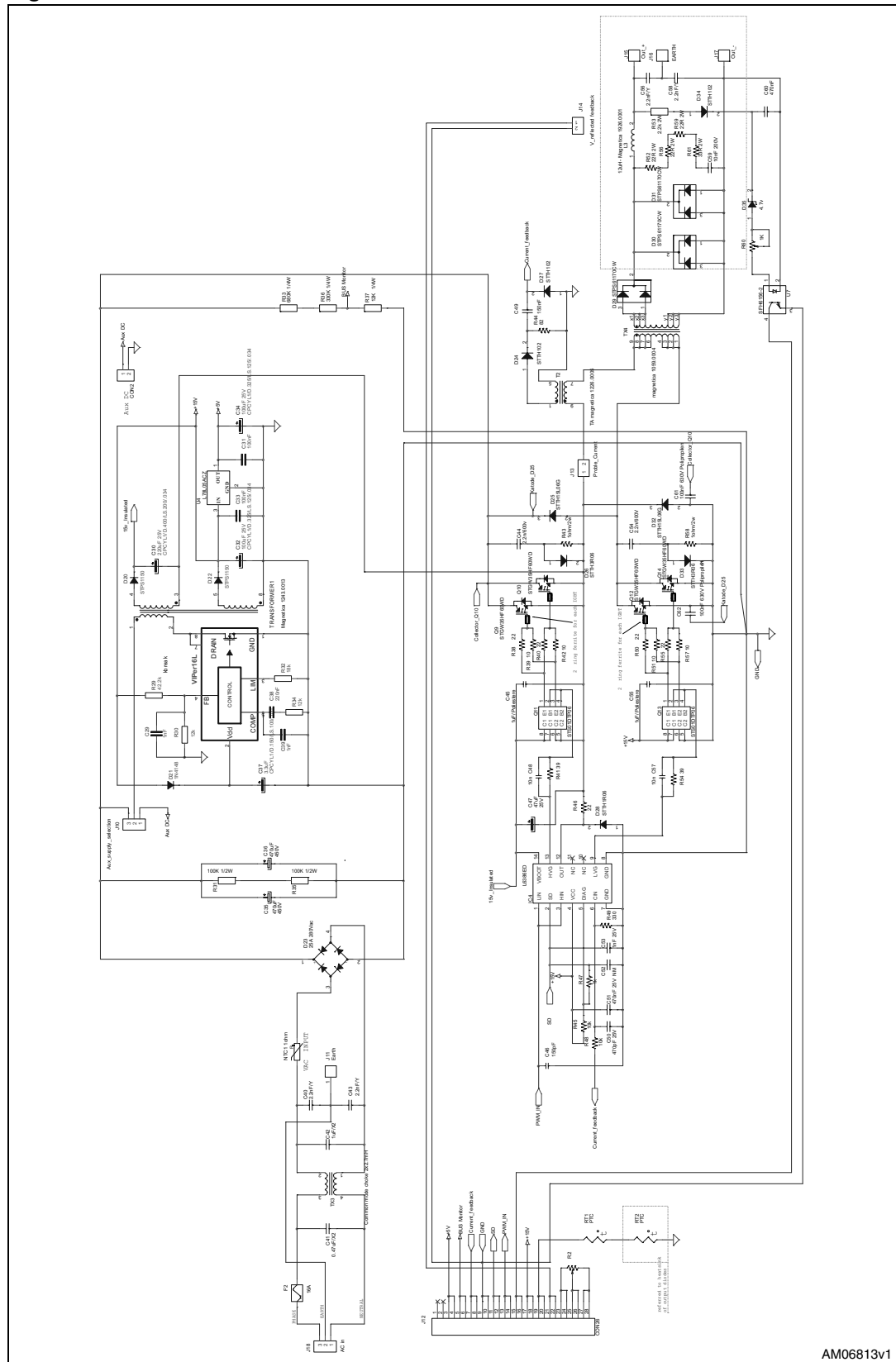

AM06813v1

5.2 Control board schematic description

Figure 9. Control board schematic

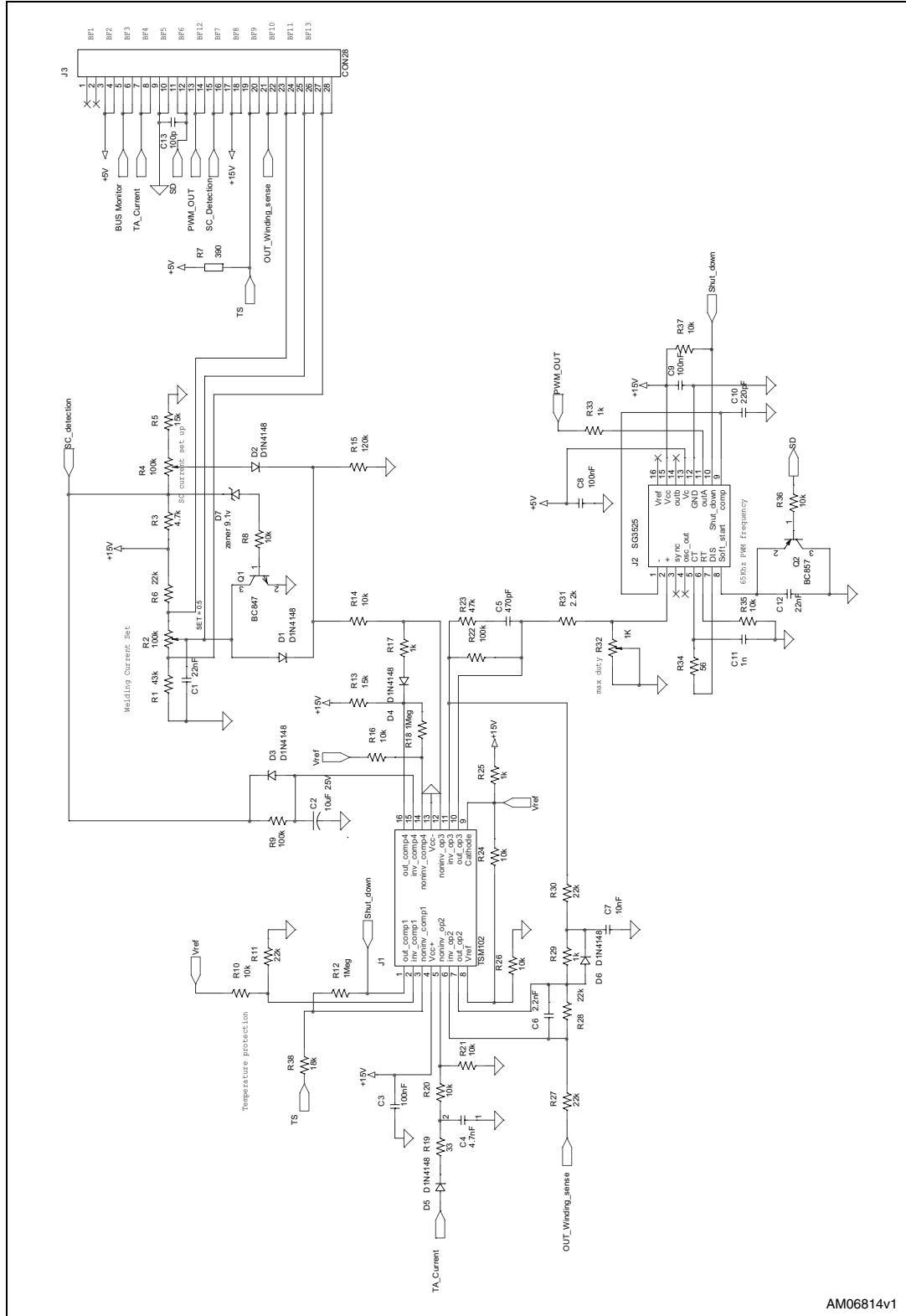

AM06814v1

In [Figure 9](#) the schematic diagram of the control board is shown.

The control of the MMA power supply is based on some analog blocks.

Three basic blocks can be identified in the schematic of the welding machine control board.

- Analog amplification and computation block based on the TSM102
- PWM generator based on the SG3525
- Welding current dynamic reference based on discrete components

The analog amplification and computation block is based on the TSM102. This chip has two operational amplifiers, two voltage comparators and a voltage reference inside. The operational amplifiers are used to implement an analog current control composed by a PID and an integrator, (see [Figure 5](#)).

One of the two amplifiers is used to implement the error amplifier for the current control. A voltage representative of the output welding current is subtracted to a voltage level representative of the wanted target current level. The error signal is amplified and represents the PWM level to be set as the control variable to the power converter.

This is a standard PID control.

As already explained in [Section 4](#), the measurement of the output current is obtained through an indirect estimation. The value of the peak current on the primary side of the ferrite transformer, measured by current transformer T2, is sent in input to an analog adder realized by the op amp inside the TSM102 connected to pins 5, 6, and 7, non inverting input, inverting input, and output, respectively. The same op amp is used as an integrator to calculate the current output ripple value. This final signal, representative of the output welding current, is present on C7. The second op amp, connected to pins 12, 11, and 10 of the TSM102, implement the error amplifier for the final current regulation block.

The output error signal is finally sent to the PWM generator SG3525. This chip provides an output square wave signal with a duty cycle value proportional to the voltage present on pin 2. The frequency of this signal can be set by the value of C11 and R35. The signal SD coming from the power board is pulled down by the comparator inside the L6386E driver in case of overcurrent detection. The PNP Q2, in this case, immediately discharges C12, in these conditions the PWM generator switches off the output. As the overcurrent condition elapses the SD signal is released, Q2 switches off and the slow charge of C12 implements a soft-start.

By using the voltage comparator connected to pins 1, 2, and 3 of J1 (TSM102) an overtemperature protection is implemented. The voltage signal TS, coming from a temperature sensor, is compared to a fixed voltage obtained by the resistive partitions R10 and R11. As the temperature on the heatsink goes over the threshold, the signal Shut_down is pulled down and the PWM generator is switched off.

The second comparator inside the TSM102, connected to pins 16, 15, and 14, is used to implement an anti-stick circuit. At startup, when the electrode comes into contact with the metal piece and the arc is not yet on, it's possible that the electrode may stick to the metal piece being welded. Under this condition a hard short-circuit is present at the output of the generator. This condition, sensed by the optocoupler U7, discharges the capacitor C2 through R9. This gives a delay of about two seconds before the output of the comparator (pin 16) goes low, setting the target current coming from the potentiometer to a low level. This protects the generator and allows the operator to remove the electrode from the metal piece under a low current condition (avoiding sparks).

The last block to describe is the welding current dynamic reference which is based on the optocoupler and the bipolar transistor Q1 plus some passive components and signal diodes.

The welding current dynamic reference block is dedicated to giving the right target to the current control, according to the MMA process status.

During the welding process some fused metal drops can cause a momentary short-circuit of the plasma; this causes the electrode to stick to the metal piece being welded. This forces the operator to remove mechanically the electrode from the metal, or simply cause a discontinuous plasma action which gives bad results in terms of weld quality. To avoid these phenomena, an automatic and dynamic quick increase in the welding current must be performed, as a shortcut condition is sensed by the optocoupler in order to fuse, as soon as possible, any cause that tends to switch OFF the plasma.

During this momentary short-circuit, the voltage drops at the output cause the bipolar phototransistor inside the optocoupler to be switched off. Q1 is immediately switched on, clamping the welding current reference set by the trimmer R2 to its VCESAT. In this condition the voltage reference set by the trimmer R4 is free to get into the current regulation block. Otherwise, under normal welding conditions, the bipolar inside the optocoupler is ON so the voltage set by R4 is low and the voltage set by R2 is free to enter the current regulation block.

The result is the possibility to differentiate the reference for the current control in the two different working conditions: plasma ON (voltage at the output in a valid range), short-circuit (plasma OFF low voltage at the output).

This behavior is totally automatic and dynamic thanks to the signal generated by the optocoupler U7.

Two small trimmers can be found on the control board; short-circuit current (R4) and maximum duty cycle (R32).

A further trimmer is dedicated to setting the welding current during normal operation (R2). The electrical connection of R2 is also replicated on the power board so it is possible, using wire assembling, to mount it on the front panel of the welding machine for easy setting during operation.

The objective of the maximum duty cycle trimmer is to set the maximum duty cycle in open load condition. In fact, in open load condition, the current control forces the maximum possible duty cycle (50 % for a forward converter). Acting on this trimmer, it is possible to limit the duty cycle to a value different from the maximum allowed by the PWM generator.

6 Revision history

Table 1. Document revision history

Date	Revision	Changes
06-Sep-2010	1	Initial release.

Please Read Carefully:

Information in this document is provided solely in connection with ST products. STMicroelectronics NV and its subsidiaries ("ST") reserve the right to make changes, corrections, modifications or improvements, to this document, and the products and services described herein at any time, without notice.

All ST products are sold pursuant to ST's terms and conditions of sale.

Purchasers are solely responsible for the choice, selection and use of the ST products and services described herein, and ST assumes no liability whatsoever relating to the choice, selection or use of the ST products and services described herein.

No license, express or implied, by estoppel or otherwise, to any intellectual property rights is granted under this document. If any part of this document refers to any third party products or services it shall not be deemed a license grant by ST for the use of such third party products or services, or any intellectual property contained therein or considered as a warranty covering the use in any manner whatsoever of such third party products or services or any intellectual property contained therein.

UNLESS OTHERWISE SET FORTH IN ST'S TERMS AND CONDITIONS OF SALE ST DISCLAIMS ANY EXPRESS OR IMPLIED WARRANTY WITH RESPECT TO THE USE AND/OR SALE OF ST PRODUCTS INCLUDING WITHOUT LIMITATION IMPLIED WARRANTIES OF MERCHANTABILITY, FITNESS FOR A PARTICULAR PURPOSE (AND THEIR EQUIVALENTS UNDER THE LAWS OF ANY JURISDICTION), OR INFRINGEMENT OF ANY PATENT, COPYRIGHT OR OTHER INTELLECTUAL PROPERTY RIGHT.

UNLESS EXPRESSLY APPROVED IN WRITING BY AN AUTHORIZED ST REPRESENTATIVE, ST PRODUCTS ARE NOT RECOMMENDED, AUTHORIZED OR WARRANTED FOR USE IN MILITARY, AIR CRAFT, SPACE, LIFE SAVING, OR LIFE SUSTAINING APPLICATIONS, NOR IN PRODUCTS OR SYSTEMS WHERE FAILURE OR MALFUNCTION MAY RESULT IN PERSONAL INJURY, DEATH, OR SEVERE PROPERTY OR ENVIRONMENTAL DAMAGE. ST PRODUCTS WHICH ARE NOT SPECIFIED AS "AUTOMOTIVE GRADE" MAY ONLY BE USED IN AUTOMOTIVE APPLICATIONS AT USER'S OWN RISK.

Resale of ST products with provisions different from the statements and/or technical features set forth in this document shall immediately void any warranty granted by ST for the ST product or service described herein and shall not create or extend in any manner whatsoever, any liability of ST.

ST and the ST logo are trademarks or registered trademarks of ST in various countries.

Information in this document supersedes and replaces all information previously supplied.

The ST logo is a registered trademark of STMicroelectronics. All other names are the property of their respective owners.

© 2010 STMicroelectronics - All rights reserved

STMicroelectronics group of companies

Australia - Belgium - Brazil - Canada - China - Czech Republic - Finland - France - Germany - Hong Kong - India - Israel - Italy - Japan - Malaysia - Malta - Morocco - Philippines - Singapore - Spain - Sweden - Switzerland - United Kingdom - United States of America

www.st.com

